

Campsites, Caravan Parks & Static Homes



This factsheet gives information on how to comply with the water regulations when designing a new water system for holiday parks, static homes, campsites and prefabs. It has been developed in line with the Water Supply (Water Fittings) Regulations 1999 to offer guidance for compliance with the regulations. Please read it carefully and pass it to your plumber or whoever is carrying out the work on your property to ensure that the work is carried out competently.

Company metering requirements

On large sites such as caravan parks or holiday parks it is likely that they would have a private water main installed around the site with individual supplies connected to the bulk water main supply. SES Water will fit a water meter on the boundary of the site for billing purposes and to enable the site to be logged and monitored for leakage and high consumption that may occur.

The owner of the site may choose to fit approved individual water meters to each home for charging purposes, however this metering would be controlled by the site owner. On smaller developments it is likely that every individual property could have a new water supply pipe that would be fitted with a water meter at the site boundary. Developer services will advise you on the most suitable option for metering a new development site at the quotation stage of the new connection process.

Laying the new water supply pipe

The pipework and metering design for any new site must be agreed with SES Water's Developer Services team. If the site requires a bulk water main on site with individual connections, then this work must be carried out by an approved contractor. It must comply with the water regulations and would require chlorination in line with our company chlorination policy.

For normal ground conditions blue MDPE pipe (compliant with Reg 4.1.a of the Water Supply (Water Fittings) regulations 1999) should be used. Where the ground is classified as contaminated (e.g. reclaimed land sites) or the supply pipe is close to a petrol or oil source, then a suitable barrier pipe (compliant with Reg 4.1.a of the Water Supply (Water Fittings) must be used.

The pipe diameter for an individual premises, should be 25mm as a standard size, larger diameter pipes may be permitted in exceptional circumstances if agreed by SES Water. The pipe to any individual premises, must be laid to a minimum depth of 750mm all the way along the trench from the boundary and up to a position where it will enter into the raised property such as a caravan or static home.

The pipe should be laid in one continuous length without any joints. If joints are unavoidable due to a long distance, then we strongly recommend fitting a chamber and lid over any joints to enable access during a leak investigation.

The position for entry up to any raised premises should be at a suitable position underneath the property to help protect the pipe from any contact with direct sunlight and from freezing. If it is likely that pitches will have homes moved around on a regular basis, it is recommended to install a stop valve on the pipe underground in front of the pitch or just underneath the property.

A pipe that is left disconnected and open ended must be sealed to prevent contaminants from entering the pipe until it is reconnected. If the pipe is going to be left unused for a long period of time, then it must be fitted with an approved transitional cap end fitting and should be thoroughly flushed through before reconnecting the pipe. The pipe may need to be re-chlorinated depending on the duration.

The method for suitably ducting and insulating the pipework where it enters a raised static home is shown in the two diagrams on the next page.

For further information contact the Water Regulations team at
SES Water, London Road, Redhill RH1 1LJ
Email: waterregulations@seswater.co.uk

water fact sheet

Campsites, Caravan Parks & Static Homes

Ducting and insulating the pipe

Water supply for mobile homes

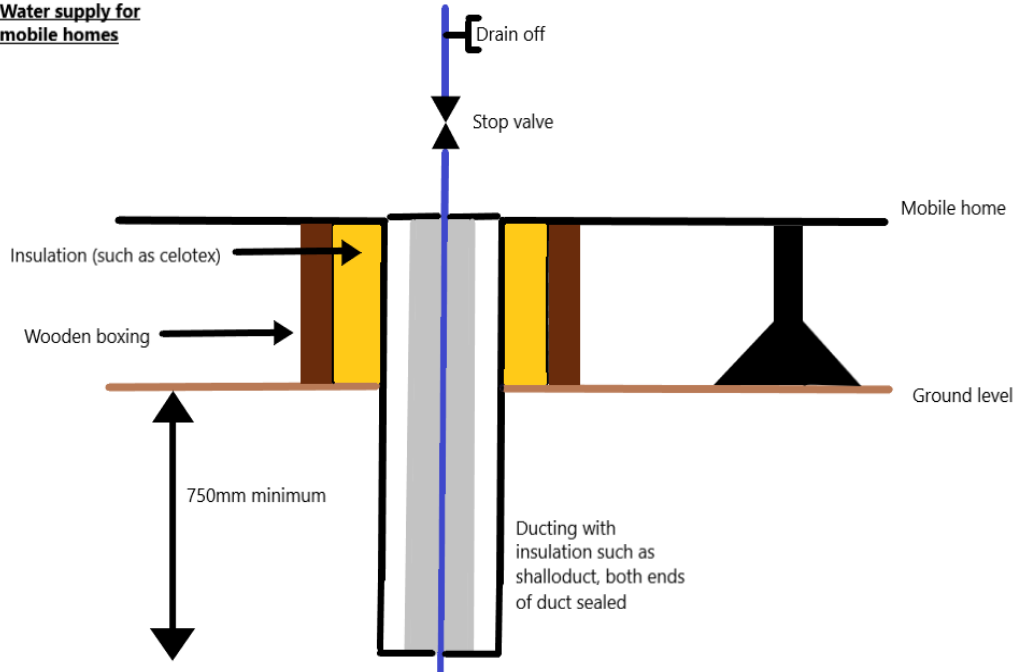

Water Supply for Mobile Homes

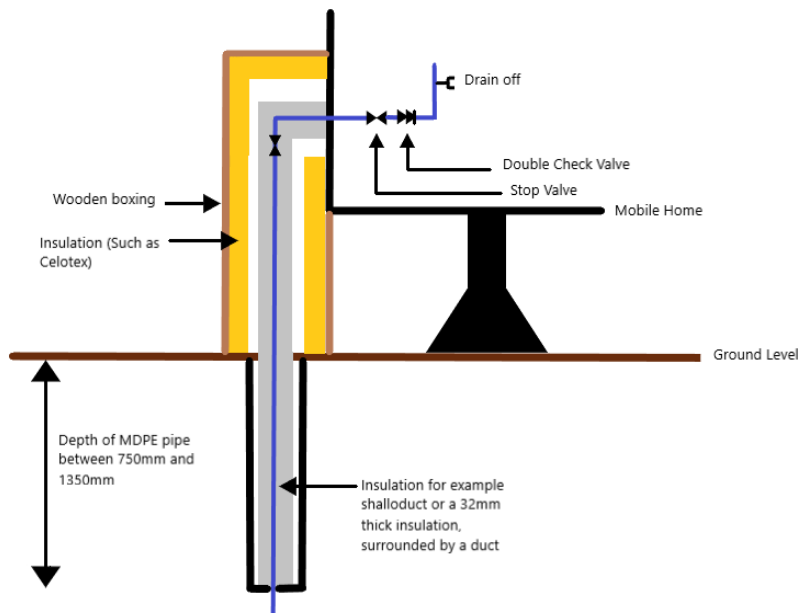

Campsites, Caravan Parks & Static Homes

Internal plumbing requirements

There must be an approved stop valve and drain off valve fitted in an easily accessible place inside the property close to where the pipe enters. The entire system can be drained down using the drain off valve during long periods when the property is not occupied.

Any outside taps must have an approved isolation valve and double check valve fitted inside the property on the feed supplying the hose union tap (outside tap). If it is not possible to fit a double check valve on the pipe inside the property, then an HUK 1 hose union tap is acceptable as it has built in backflow protection. However, this type of tap is not recommended as they are susceptible to leaking from the frost plug during prolonged cold spells. It should also be noted that it is best practice to isolate the tap during winter by shutting off the stop valve and draining down if it is not going to be used.

Any appliances such as a washing machine or dishwasher must have an approved double check valve fitted next to the hose valve for backflow protection purposes. Showers must have a retaining ring on the shower rail to restrain the head or fit shorter hoses to ensure that the head cannot reach the floor of the shower tray and most importantly ensure that it cannot reach the toilet which is a fluid category 5 risk and serious contamination risk. Toilets require a type AUK 1 arrangement with an AG air gap.

It is recommended that the internal pipework is insulated to BS 5422 to minimise any undue warming or freezing of pipes that could result in potential water quality issues and unnecessary waste of water. Free to access insulation calculators are available online which should be used when considering different insulation materials.

The following images provide example of the fittings and applications detailed above:



[Example of approved stop valve]



[Example of approved drain valve]



[Example of approved double check valve]

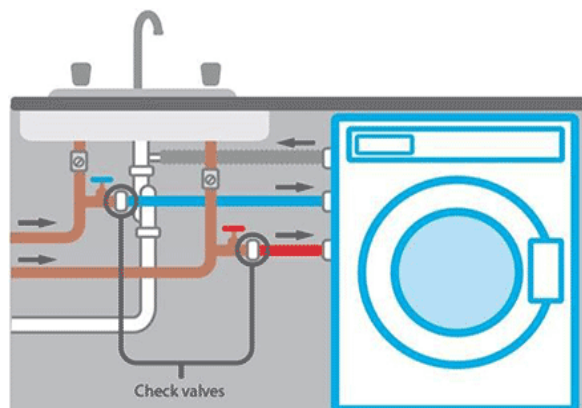

[Example of double check valve arrangement for appliances]

For further information contact the Water Regulations team at
SES Water, London Road, Redhill RH1 1LJ
Email: waterregulations@seswater.co.uk

Campsites, Caravan Parks & Static Homes

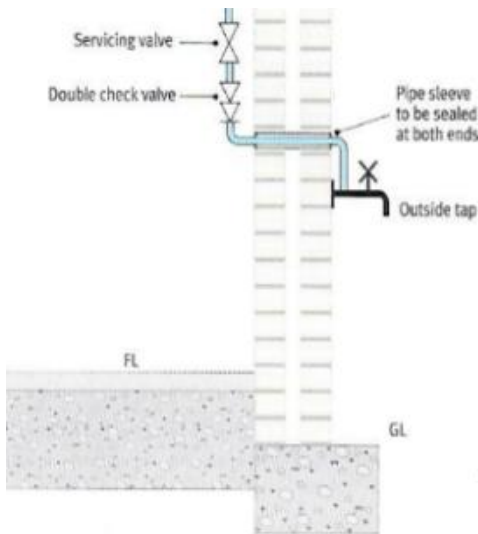

[Example of outside tap set up]



[Compliant Type AUK 1 WC arrangement incorporating an AG air gap]



[Example of a hose union tap]

Bin store tap requirements

Any hose union tap and hoses used in bin store areas will be considered a fluid category 5 risk unless a risk assessment by the relevant water undertaker determines otherwise. If a hose union tap is fitted in a bin store area then the tap can only be supplied with water through a system incorporating a type AA, AB, AD or AUK 1 air gap arrangement. An alternative solution for a tap in this vicinity is to fit a non-threaded bit tap or non-concussive tap with a double check valve on the pipe and erect a sign next to the tap stating it is for BUCKET FILL ONLY. This tap is not threaded and therefore a hosepipe cannot be attached to it. A hose union tap with a double check valve in a bin store area for the purpose to allow the landlord to wash down bin store areas must not be installed.



[Example shower with retaining ring set up]



[Example of a non-threaded tap]

Campsites, Caravan Parks & Static Homes



[Example of an approved Fluid Category 5 break cistern system with booster pump]

Chemical disposal point

A chemical disposal unit on a campsite, caravan park, or other holiday site is a high contamination risk area, and therefore care must be taken when installing a water supply at this location.

A mains-fed threaded hose union tap is not allowed for this use due to the high contamination risk. The safest way to clean them is by flushing them out with a bucket of water that is filled from a non-threaded tap with a sign erected stating BUCKET FILL ONLY. If a permanent water set up is required above the chemical flush unit then the design must incorporate a water supply through an AA, AB, AD or AUK 1 air gap. A type AUK 1 air gap with an interposed cistern is suitable. If the tap does require use with a pressurised hosepipe then follow the guidance for a bin store tap with a fluid category 5 break cistern.

Please contact our Water Regulations team for more details and guidance at: waterregulations@seswater.co.uk.



[Example of a chemical disposal point]

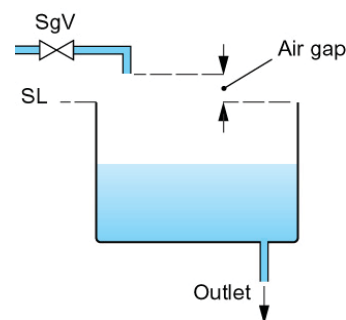

[Example of a Type AA air gap]

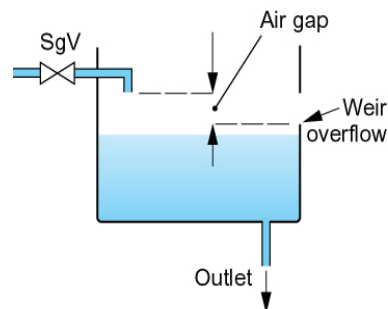

[Example of a Type AB air gap]

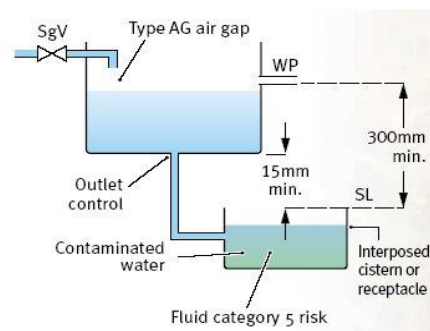

[Example of a Type AUK1 air gap]